

# MAURER MSM<sup>®</sup> Swivel Joist Expansion Joints

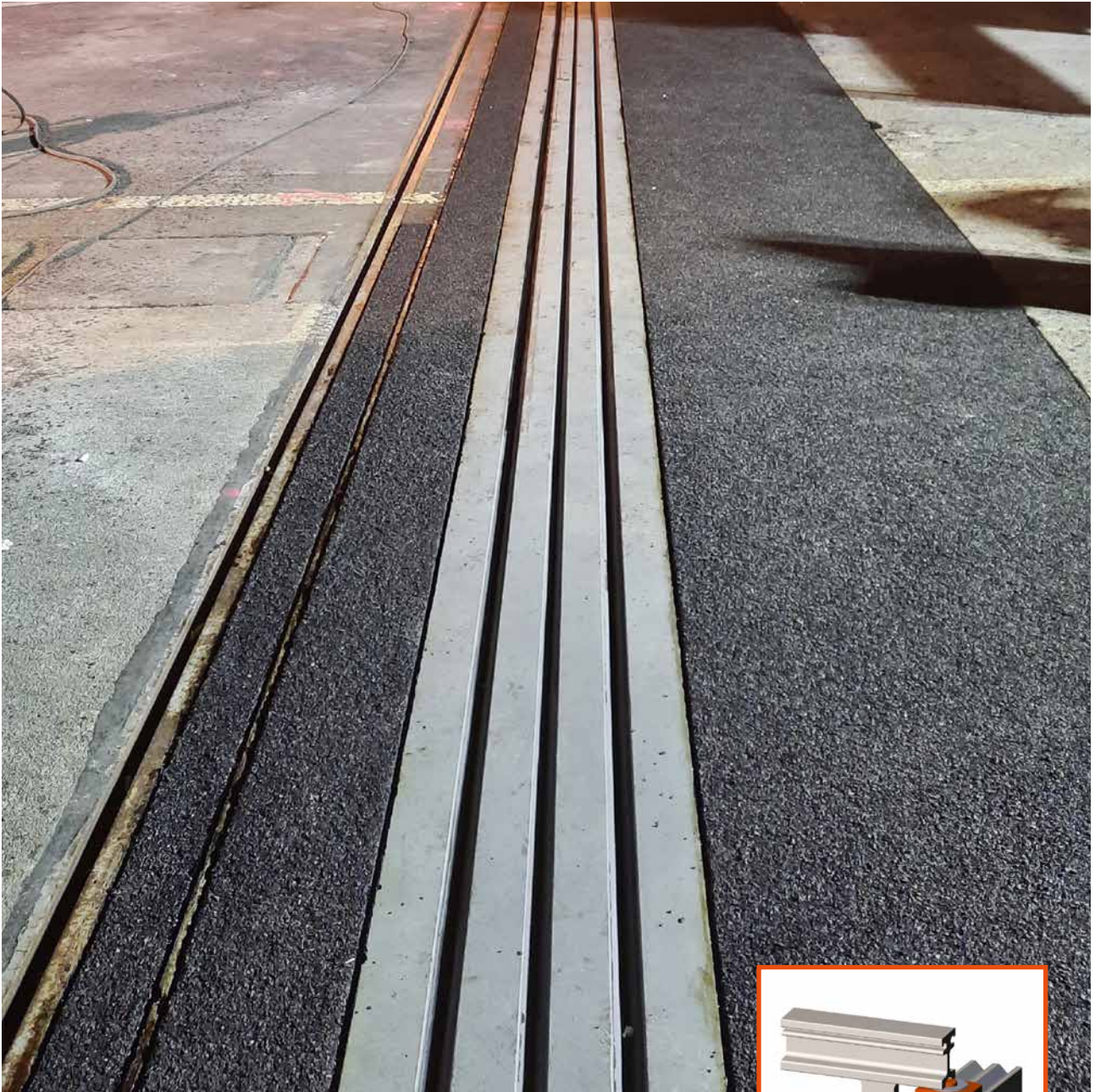

MAURER MSM<sup>®</sup> Swivel Joist Expansion Joints

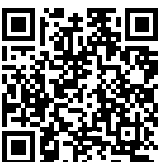

## MAURER Expansion Joints for Roadway Bridges

Expansion joints for roadway bridges are the flexible connection between superstructure units or the bridge superstructure and abutments. These must accommodate all possible movements and rotations from traffic impacts, wind, temperature differences, creep and shrinkage (concrete), seismic events, etc. and guarantee a safe transfer of traffic loads. MAURER

Expansion Joints can be designed for all bridge types – such as steel, reinforced concrete, prestressed concrete and steel-concrete composite bridges. Additionally, they can be used regardless of the bridge construction such as single-span beam bridge, suspension bridge, cable-stayed bridge etc.



© Hajo Dietz



© Hajo Dietz

## MAURER MSM® Swivel Joist Expansion Joints

This is an improvement to the MAURER Swivel Joist Expansion Joint system that has performed well for decades by utilizing the latest technology for the fabrication of the sliding bearings. Due to its special kinematic control, the MAURER MSM® Swivel Joist Expansion Joint continually adapts to structural deformations and rotations. Not only does the joint

accommodate bridge movements in the longitudinal direction of the carriageway, but also movements in the transverse and vertical directions. The joint also easily handles rotations of the bridge about the three spatial axes. The kinematic control principle produces gap widths evenly distributed between the centre beams depending on the bridge movements.

### Main characteristics

- Precise kinematic control of centre beam spacing
- Fatigue resistant design
- Six degrees of freedom movement with no size limits
- Safe for traffic – secure and durable transmission of traffic loads
- Durable and low friction sliding bearings
- Service life of more than 50 years
- Cost effective and sustainable design
- Movement capacities up to 100 mm (for DS 65 mm acc. to TL/TP FÜ) in service and 160 mm for seismic condition

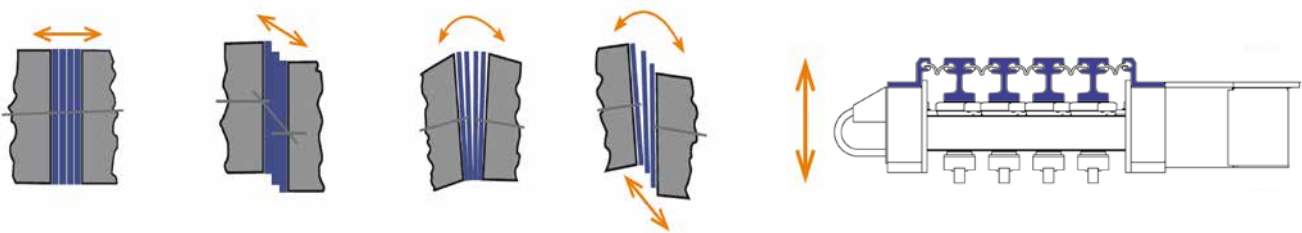

The MAURER Swivel Joist Expansion Joint has been used on signature bridge projects all over the world. One example is the Russky Bridge, which is one of the largest cable-stayed bridges in the world with a span of 1,104 m.

### Russky Bridge, Vladivostok, Russia

MAURER Swivel Joist Expansion Joints XS24 with movements of 2,400 mm and an anti-skid surface.

The expansion joint is designed for a temperature range from - 50 °C to + 40 °C.



## MSM® CAT - The Catamaran Guide with MSM®

The prism guide, also called "CAT" guide due to its visual and functional similarity to a catamaran, facilitates a tight fitting and thus wear-free control of the expansion joint. The kinematic control principle produces gap widths evenly distributed between the centre beams depending on the bridge movements.

### Characteristics

- Guided elastic swivel joints
- Each centre beam is controlled independently
- Superstructure movements displace the support bars on the swivelling bearings
- The special geometry and the prestressed sliding spring prevent the sliding bearings from being lifted off

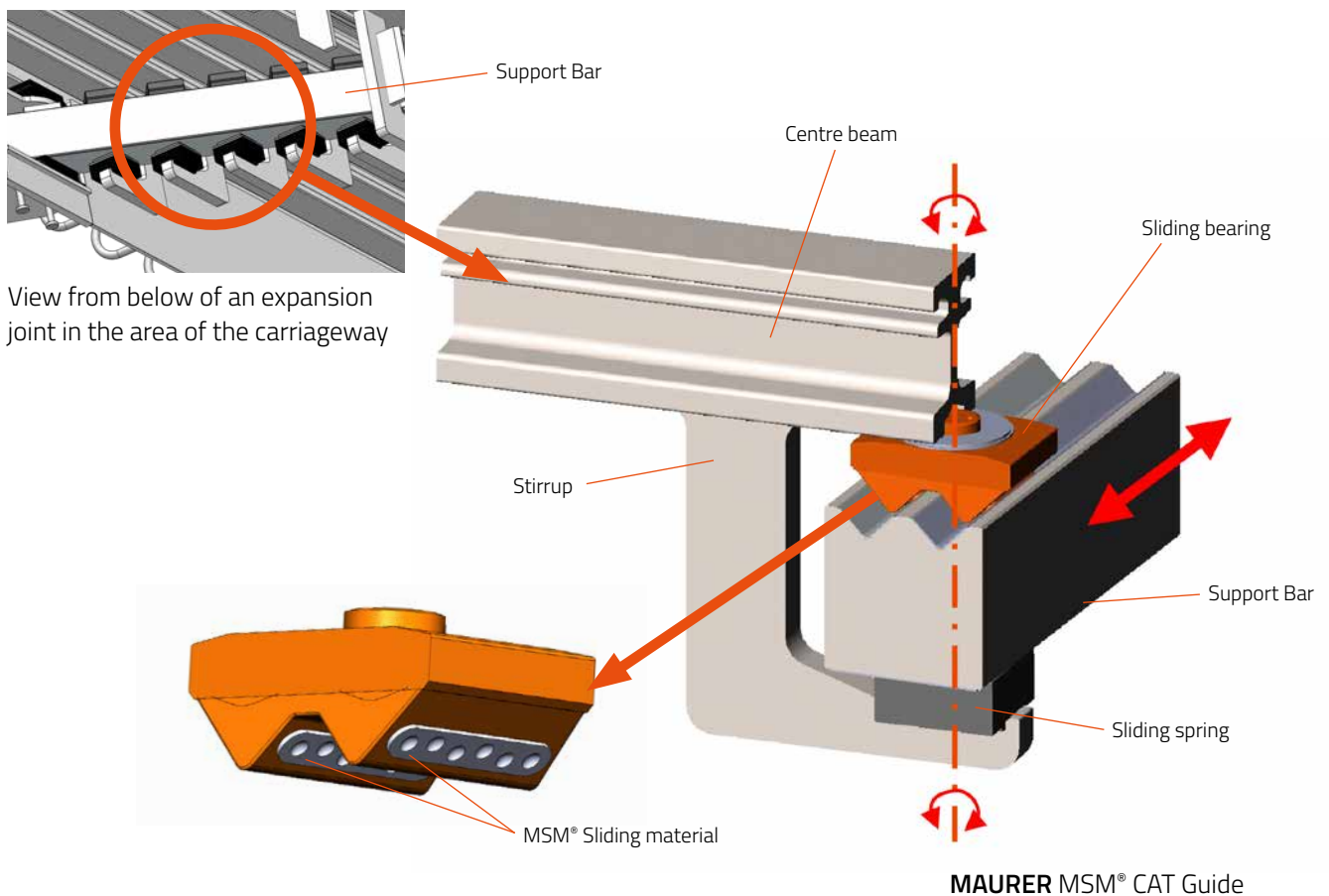

### MSM® – the special sliding material

- Patented high-performance sliding material for structural bearings acc. to EAD 050004-01-0301
- Extended service life and twice the allowable compressive stress compared to PTFE
- Without environmentally harmful components such as fluorine or chlorine
- Resistant against chemical contamination and ageing

## MAURER MSM® Swivel Joist Expansion Joint DS

The expansion joint is designed individually for each structure and can be optimally adjusted to specific requirements in terms of geometry and type of anchoring.

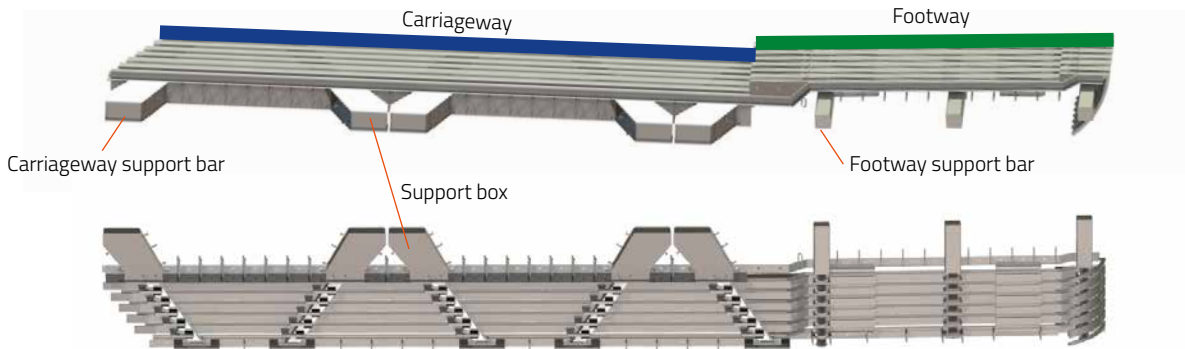

MAURER Expansion Joint DS

## MAURER MSM® Swivel Joist Expansion Joint XS

The MSM® expansion joint can optionally be equipped with rhombic elements. This mitigates the impact edges at the single gaps, which run transversely to the direction of traffic, and thus significantly reduces the impulse-like noise emissions.

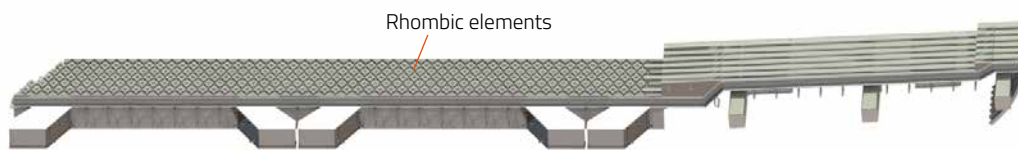

MAURER Expansion Joint XS

### Characteristics of type XS



Rhombic elements with plug welding

- Noise reduction of 50-60% compared to standard modular expansion joints
- Larger single gap widths of 100 mm possible for SLS movements
- Anti-skid surface
- Rhombic elements are typically welded on the centre beams in the factory

### Flexible noise protection system GU

Independent of the noise reduction from the top of the joint by the rhombic elements, the GU system can reduce low-frequency impulse noise emissions from below the joint which are audible over longer distances. The GU system can be opened, checked and, if necessary, cleaned by one person section by section during bridge maintenance or inspections.

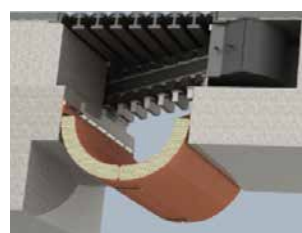

## Sealing elements

- Interlocking and frictional fixity in the edge and centre beam sections
- Seal pullout due to trapped foreign objects (such as stones, dirt, snow etc.) is impossible
- Watertight, replaceable and self-cleaning
- Can be utilized with various expansion joint designs and bridge cross sections
- A swelling rubber seal option, activated by moisture, ensures water tightness during replacement of the elements

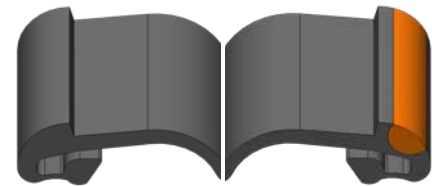

Standard

with swelling  
rubber seal

## Hybrid profiles for centre beams, edge profiles and rhombic elements



The upper area of the expansion joint, steel elements, which is exposed to moisture and wet debris, is made of stainless steel.

## Curved upturn

The change of elevation at the joint upturn can be produced by bent steel profiles to eliminate the lower welded connection. This detail avoids discontinuity along the steel profile and improves water tightness.

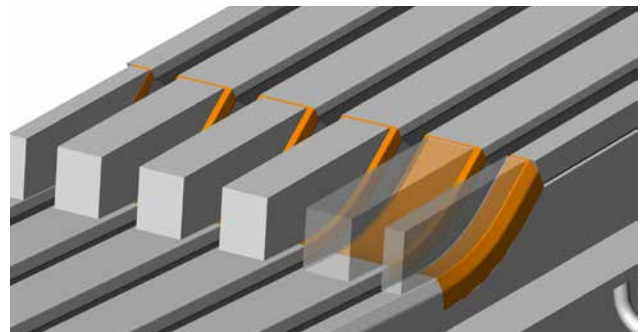

## Pedestrian and bicycle comfort in footway area

The footway area of the MAURER MSM® Swivel Joist Expansion Joints is safe for pedestrian and bicycle traffic. Additional measures such as checkered stainless steel plates or sealing elements with an additional intermediate web (hump seal) increase user safety if necessary.

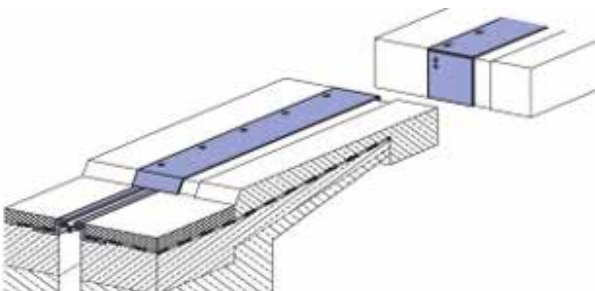

Closed surface by use of cover plate

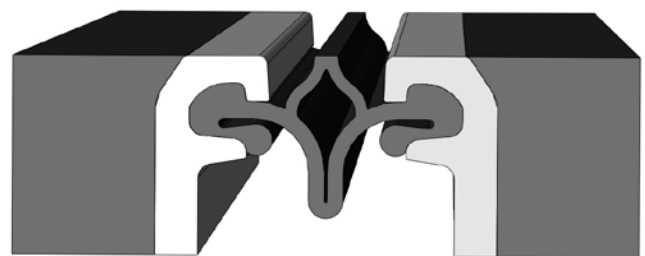

Hump seal for the footway area

## Allowable movements according to TL/TP FÜ (German Approval)

The allowable movements of types DS and XS expansion joints are listed in the technical approval and the principles for calculating movement capacities are listed here.

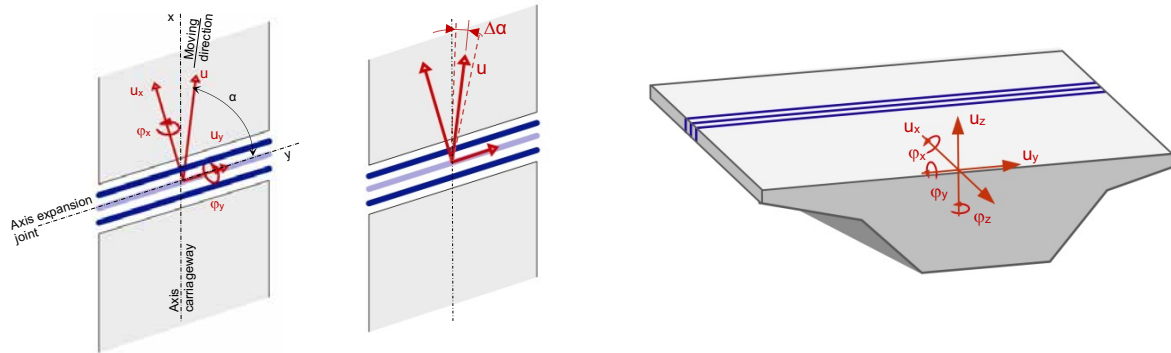

DS Type (without noise reduction)		
<b>u</b>	Main direction of movement	unrestricted within $\alpha_{adm}$
<b>u<sub>q</sub></b>	Movement transverse to the main direction of movement	unrestricted within $\Delta\alpha_{adm}$
<b>u<sub>x</sub></b>	Movement at right angles to the joint axis	$n * 65 \text{ mm}$ $n * 160 \text{ mm}$ during seismic events
<b>u<sub>y</sub></b>	Movement in direction of the joint	$\pm n * 50 \text{ mm}$ , unrestricted during seismic events
<b>u<sub>z</sub></b>	Height offset of the edge profiles	$\pm n * (90 + e) * \tan(\varphi_y)$ [mm]
$\varphi_x$	Rotation about the axis at right angles to the expansion joint	$\pm \arctan(2 * \tan(\varphi_y) * n * (90 + e) / B)$ [mm]
$\varphi_y$	Rotation about the joint axis	(see tables)
$\varphi_z$	Rotation about the vertical axis	$\pm \arctan((u_{x,adm} - u_{x,given}) * 2 / B)$
$\alpha$	Angle between direction of movement and joint axis	$45^\circ \leq \alpha \leq 135^\circ$
$\Delta\alpha$	Deviation of the planned direction of movement $\alpha$	$45^\circ \leq \alpha \leq 135^\circ$
$\beta$	Angle between carriageway axis and joint axis	arbitrary
<b>e</b>	Single gap width	Centre position = 37.5 mm
<b>B</b>	Width of the bridge, measured in direction of the joint	15.0 m is chosen as an example

The sealing element must always be installed in centre position (e = 37.5 mm).

XS Type (with noise reduction)		
<b>u</b>	Main direction of movement	unrestricted within $\alpha_{adm}$
<b>u<sub>q</sub></b>	Movement transverse to the main direction of movement	(see tables)
<b>u<sub>x</sub></b>	Movement at right angles to the joint axis	$n * 95^{1)}$ mm $n * 160 \text{ mm}$ during seismic events
<b>u<sub>y</sub></b>	Movement in direction of the joint	$u_y \leq \pm 0,6 * e * n \leq \pm n * 50 \text{ mm}$ $u_y \leq \pm 0,6 * e * n$ during seismic action
<b>u<sub>z</sub></b>	Height offset of the edge profiles	$\pm n * (90 + e) * \tan(\varphi_y^2)$
$\varphi_x$	Rotation about the axis at right angles to the expansion joint	$\pm \arctan(2 * \tan(\varphi_y) * n * (90 + e) / B)$ [mm]
$\varphi_y$	Rotation about the joint axis	(see tables)
$\varphi_z$	Rotation about the vertical axis	$\pm \arctan((u_{x,adm} - u_{x,given}) * 2 / B)$
$\alpha$	Angle between direction of movement and joint axis	$60^\circ \leq \alpha \leq 120^\circ$
$\Delta\alpha$	Deviation of the planned direction of movement $\alpha$	$60^\circ \leq \alpha \leq 120^\circ$
$\beta$	Angle between carriageway axis and joint axis	arbitrary
<b>e</b>	Single gap width	Centre position = 52.5 mm
<b>B</b>	Width of the bridge, measured in direction of the joint	15.0 m is chosen as an example

The sealing element must always be installed in centre position (e = 52.5 mm).

- 1) Possible additional measures in footways without noise protection elements and pedestrian use
- 2) Change of inclination with longitudinal slope and deflection of support bars are not included

## Recess dimensions

Values for specific project requirements will be provided on demand.

### MSM® Swivel Joist Expansion Joints DS – displacement of support bars, on one side

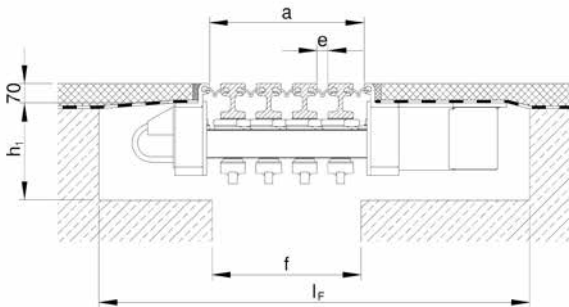

Assumed presetting dimension  $e = 30$  mm

### MSM® Swivel Joist Expansion Joints with noise reduction XS – displacement of support bars, on one side

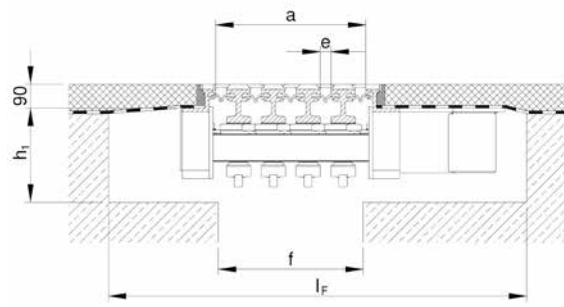

Assumed presetting dimension  $e = 50$  mm

n	Type	a [mm]	h <sub>1</sub> [mm]	f <sub>min</sub> [mm]	f <sub>max</sub> [mm]	l <sub>F</sub> [mm]	Type	a [mm]	h <sub>1</sub> [mm]	f <sub>min</sub> [mm]	f <sub>max</sub> [mm]	l <sub>F</sub> [mm]
2	DS2	150	340	115	130	995	XS2	190	340	155	170	1095
3	DS3	270	350	225	250	1165	XS3	330	360	285	310	1305
4	DS4	390	360	300	370	1290	XS4	470	370	380	450	1480
5	DS5	510	370	410	490	1450	XS5	610	380	510	590	1690
6	DS6	630	380	520	510	1610	XS6	750	390	640	730	1900
7	DS7	750	390	630	730	1780	XS7	890	400	770	870	2110
8	DS8	870	400	740	850	1940	XS8	1030	410	900	1010	2330
9	DS9	990	410	850	970	2100	XS9	1170	410	1030	1150	2500
10	DS10	1110	420	960	1090	2260	XS10	1330	420	1160	1290	2710
11	DS11	1230	420	1070	1210	2430	XS11	1450	430	1290	1430	2930
12	DS12	1350	430	1180	1330	2590	XS12	1590	430	1420	1570	3140
13	DS13	1470	430	1290	1450	2750	XS13	1730	440	1550	1710	3350
14	DS14	1590	440	1400	1570	2910	XS14	1870	450	1680	1850	3560
15	DS15	1710	450	1510	1690	3080	XS15	2010	460	1810	1990	3770
16	DS16	1830	460	1620	1810	3240	XS16	2150	470	1940	2130	3980
17	DS17	1950	470	1730	1930	3400	XS17	2290	490	2070	2270	4200
18	DS18	2070	480	1840	2050	3560	XS18	2430	510	220	2410	4410
19	DS19	2190	490	1950	2170	3730	XS19	2570	520	2330	2510	4620
20	DS20	2310	500	2060	2290	3890	XS20	2710	540	2460	2690	4830

- All dimensions are at right angles to the joint axis  $y$  and for  $u_x = n \times 65$  mm (DS) and  $u_x = n \times 95$  mm (XS)
- $n$ : number of sealing elements
- $a$ ,  $f$  and  $l$  apply to the presetting dimension  $e$  for each joint gap, they must be corrected by  $n \times \Delta e$  if the dimension  $e$  deviates
- Recesses for footway support bars, guiding support bars and pipe penetrations generally require coordination between engineer and manufacturer of the expansion joint



## MSM® Swivel Joist Expansion Joints DS – displacement of support bars, on both sides

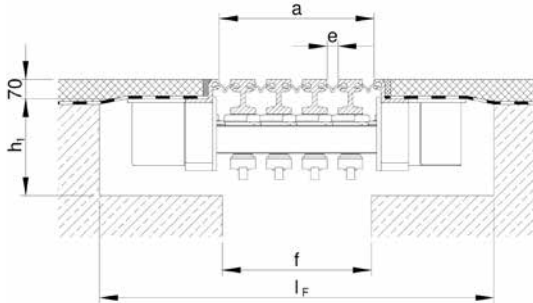

Assumed presetting dimension  $e = 30$  mm

## MSM® Swivel Joist Expansion Joints XS – displacement of support bars, on both sides with noise reduction

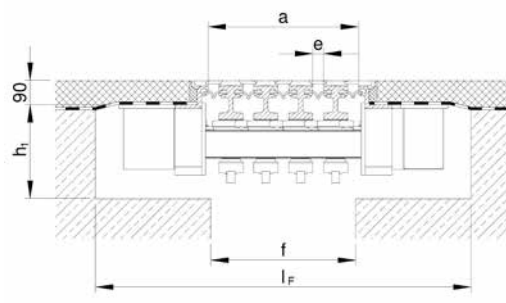

Assumed presetting dimension  $e = 50$  mm

n	Type	a [mm]	h <sub>1</sub> [mm]	f <sub>min</sub> [mm]	f <sub>max</sub> [mm]	l <sub>F</sub> [mm]	Type	a [mm]	h <sub>1</sub> [mm]	f <sub>min</sub> [mm]	f <sub>max</sub> [mm]	l <sub>F</sub> [mm]
2	DS2	150	340	115	130	935	XS2	190	340	155	170	1035
3	DS3	270	350	225	250	1105	XS3	330	360	285	310	1245
4	DS4	390	360	300	370	1220	XS4	470	370	380	450	1420
5	DS5	510	370	410	490	1390	XS5	610	380	510	590	1630
6	DS6	630	380	520	510	1540	XS6	750	390	640	730	1840
7	DS7	750	390	630	730	1710	XS7	890	400	770	870	2050
8	DS8	870	400	740	850	1880	XS8	1030	410	900	1010	2260
9	DS9	990	410	850	970	2030	XS9	1170	410	1030	1150	2470
10	DS10	1110	420	960	1090	2200	XS10	1330	420	1160	1290	2680
11	DS11	1230	420	1070	1210	2370	XS11	1450	430	1290	1430	2890
12	DS12	1350	430	1180	1330	2520	XS12	1590	430	1420	1570	3100
13	DS13	1470	430	1290	1450	2690	XS13	1730	440	1550	1710	3310
14	DS14	1590	440	1400	1570	2840	XS14	1870	450	1680	1850	3520
15	DS15	1710	450	1510	1690	3010	XS15	2010	460	1810	1990	3730
16	DS16	1830	460	1620	1810	3180	XS16	2150	470	1940	2130	3940
17	DS17	1950	470	1730	1930	3330	XS17	2290	490	2070	2270	4150
18	DS18	2070	480	1840	2050	3500	XS18	2430	510	2200	2410	4360
19	DS19	2190	490	1950	2170	3670	XS19	2570	520	2330	2510	4590
20	DS20	2310	500	2060	2290	3820	XS20	2710	540	2460	2690	4800

- All dimensions are at right angles to the joint axis  $y$  and for  $u_x = n \times 65$  mm (DS) and  $u_x = n \times 95$  mm (XS)
- $n$ : number of sealing elements
- $a$ ,  $f$  and  $l$  apply to the presetting dimension  $e$  for each joint gap, they must be corrected by  $n \times \Delta e$  if the dimension  $e$  deviates
- Recesses for footway support bars, guiding support bars and pipe penetrations generally require coordination between engineer and manufacturer of the expansion joint

## MSM® Swivel Joist Expansion Joints DS – steel connection

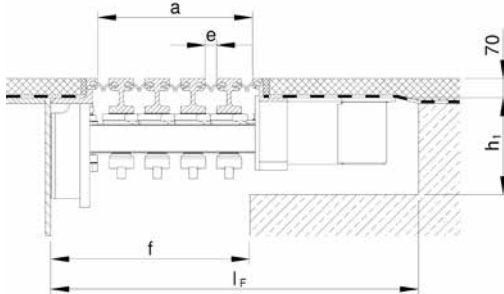

Assumed presetting dimension  $e = 30$  mm

## MSM® Swivel Joist Expansion Joints with noise reduction XS – steel connection

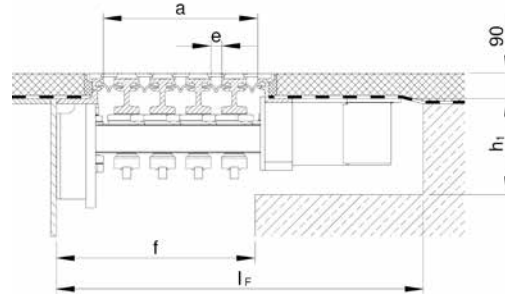

Assumed presetting dimension  $e = 50$  mm

n	Type	a [mm]	h <sub>1</sub> [mm]	f <sub>min</sub> [mm]	f <sub>max</sub> [mm]	l <sub>F</sub> [mm]	Type	a [mm]	h <sub>1</sub> [mm]	f <sub>min</sub> [mm]	f <sub>max</sub> [mm]	l <sub>F</sub> [mm]
2	DS2	150	340	300	315	780	XS2	190	340	340	355	880
3	DS3	270	350	420	435	960	XS3	330	360	480	495	1100
4	DS4	390	360	540	555	1130	XS4	470	370	620	635	1320
5	DS5	510	370	660	675	1300	XS5	610	380	760	775	1540
6	DS6	630	380	780	795	1470	XS6	750	390	900	915	1760
7	DS7	750	390	900	915	1650	XS7	890	400	1040	1055	1980
8	DS8	870	400	1020	1035	1820	XS8	1030	410	1180	1195	2210
9	DS9	990	410	1140	1155	1990	XS9	1170	410	1320	1335	2390
10	DS10	1110	420	1260	1275	2160	XS10	1330	420	1460	1475	2610
11	DS11	1230	420	1380	1395	2340	XS11	1450	430	1600	1615	2840
12	DS12	1350	430	1500	1515	2510	XS12	1590	430	1740	1755	3060
13	DS13	1470	430	1620	1635	2680	XS13	1730	440	1880	1895	3280
14	DS14	1590	440	1740	1755	2850	XS14	1870	450	2020	2035	3500
15	DS15	1710	450	1860	1875	3030	XS15	2010	460	2160	2175	3720
16	DS16	1830	460	1980	1995	3200	XS16	2150	470	2300	2315	3940
17	DS17	1950	470	2100	2115	3370	XS17	2290	490	2440	2455	4170
18	DS18	2070	480	2220	2235	3540	XS18	2430	510	2580	2595	4390
19	DS19	2190	490	2340	2355	3720	XS19	2570	520	2720	2735	4610
20	DS20	2310	500	2460	2475	3890	XS20	2710	540	2860	2875	4830

- All dimensions are at right angles to the joint axis  $y$  and for  $u_x = n \times 65$  mm (DS) and  $u_x = n \times 95$  mm (XS)
- $n$ : number of sealing elements
- $a$ ,  $f$  and  $l$  apply to the presetting dimension  $e$  for each joint gap, they must be corrected by  $n \times \Delta e$  if the dimension  $e$  deviates
- Recesses for footway support bars, guiding support bars and pipe penetrations generally require coordination between engineer and manufacturer of the expansion joint

## Quality and Specifications

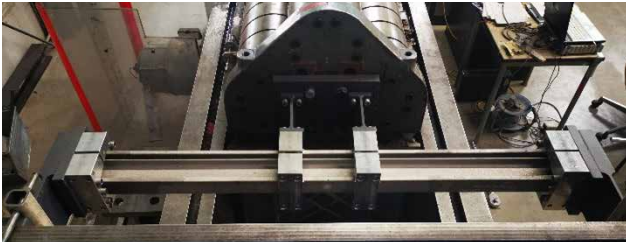

Fatigue test



Drive-over test

### Excerpts from the testing programme

#### Component tests

- Load capacity and relaxation of bearings and springs
- Fatigue resistance and wear or abrasion of bearings/ springs
- Fatigue strength of the metallic components

#### Tests on the joint assembly

- Water tightness
- Movement capacity and seal (self-)cleaning capability
- In-situ drive-over tests regarding the dynamic behaviour from traffic loads

### Technical specification summary

- TL/TP FÜ (03/2021)
- ZTV-ING (03/2021)
- EAD 120113-00-0107, Modular Expansion Joints for Road Bridges
- EAD 120109-00-0107, Nosing Expansion Joints for Road Bridges
- DIN EN 1990, Principles of structural planning
- ETA-06/0131, Spherical and cylindrical bearings with special sliding material made of UHMPE (Ultra High Molecular Weight Polyethylene)
- DIN EN 1090-2, Execution of steel structures and aluminium structures
- DIN EN ISO 9001, Quality management system
- DIN EN ISO 14001, Environmental management systems
- DIN EN ISO 3834-2, Quality requirements for fusion welding of metallic materials
- AASHTO LRFD Bridge Construction Specifications



### Third-Party Inspection

- Testing at independent universities with notified body
- Quality audits in cooperation with the client, if requested

## References

### 1915 Canakkale Bridge, Turkey

For the world's longest suspension bridge with a length of 3,869 m and a pylon height of 318 m, four MAURER MSM® Swivel Joist Expansion Joints XS28 (max. movement 2,800 mm) were supplied and installed.

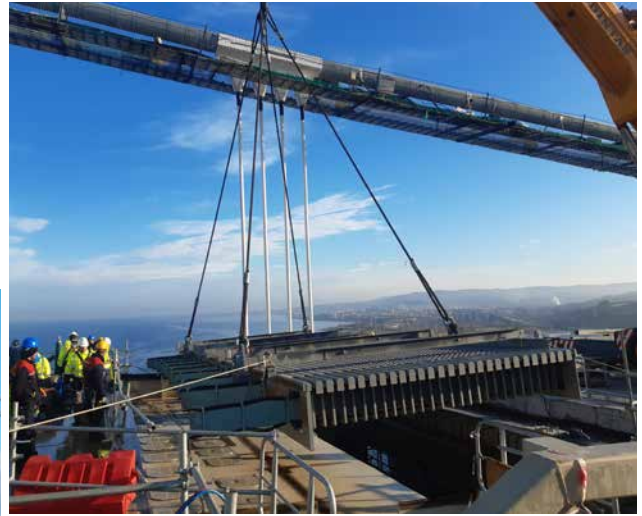

### D3 Hodejovice – Trebonin, Czech Republic

New construction of a road bridge with two XS5 (max. movement 500 mm) and six XS6 (max. movement 600 mm).

